

Application of GRC permanent formwork

Z. DONG

Nanjing Beilida Industry Co., Ltd

Abstract

GRC permanent formwork can be used in reinforced concrete projects to replace traditional formworks such as wood and steel formwork etc. It is modularly manufactured in the factory and can be quickly assembled on-site. Being an environment-friendly material, the main benefits include reducing construction time, saving formworks and formwork material, saving energy and achieving fair-face concrete finish etc. This paper introduces the application of GRC permanent formwork in the Hohhot East Coach Station Service Building in the aspect of product characteristics, installation of support and concrete casting etc.

Keywords: GRC permanent formwork, installation, casting concrete

INTRODUCTION

As a decoration material, the applications and features of Glassfibre Reinforced Concrete (GRC) are well introduced by many papers, however, as a permanent formwork, the applications are rarely talked about. With the practical experience in construction management of Hohhot bus station complex service building, the author summarizes some actual practices in terms of design, fabrication, installation and concreting, including formwork features, production organization, support installation and fastening method and so on.

The project is composed of two floors above the ground and one basement underground, its total construction area is (above the ground is 15519) [Figure 1]. The building inner structure is made of frame structure, while its envelope and roof are made of both frame structure and steel structure, the two parts are built on the same foundation but are independently.



Figure 1. Impression drawing

The longest span is 72.518m. The external reinforced concrete structure is featured with curved profiles, larger cross sections and fair-face finish. One piece of GRC formwork is about 6. totally

about 14, is used for the construction. Please refer to the above diagrams for the envelope and roof. For this project, the GRC formwork is mainly used for the beam-post reinforced concrete structure of the envelope and roof. Before our construction, the building foundation and internal frame structure are already finished.

PRODUCT FEATURES

As mentioned above, the GRC formwork is mainly used for envelope and roof beam-post concrete frame structure which shapes like a hexagon at its cross section. It is composed of two parts: an arc profile numbered YZ and an inverted cone profile numbered XZ, which should be connected together precisely without any error and reinforced by transverse beams. A 3D Rhinoceros Model is established based on design drawings [Figure 2].

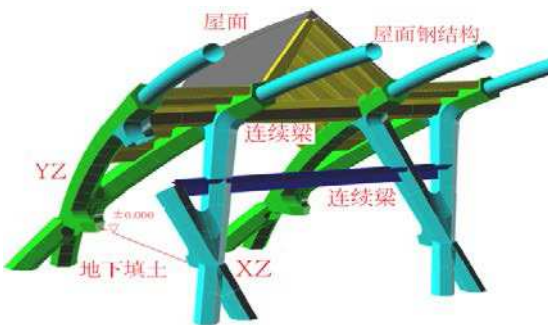

Figure 2. 3D Model of the formwork

The installation, support and fastening methods are based on reinforcement assembling and concrete pouring. The product design and connection gap design are based on cross section profiles [Figure 3].

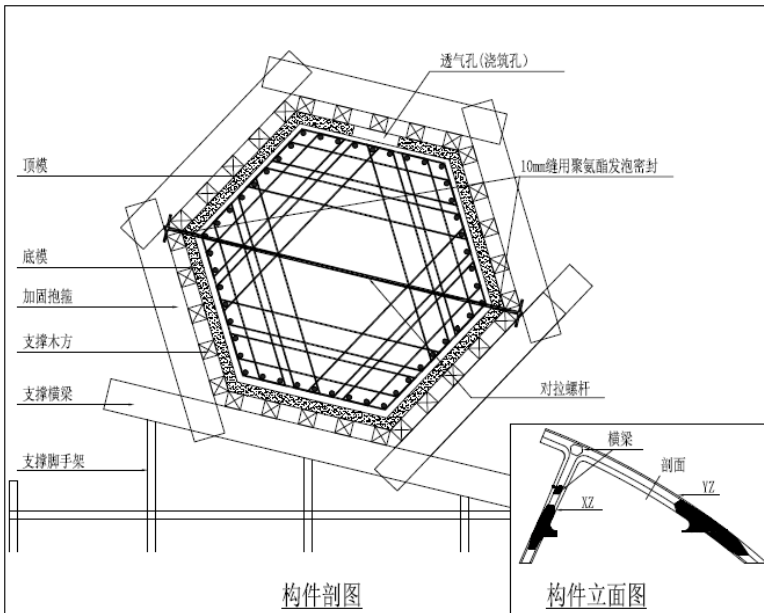

Figure 3. Section of the construction

This paper focus on YZ plane, which is the most typical and difficult one in the whole construction. The following diagram shows the product division, installation and fastening methods.

As showing on the above diagrams, the typical product is 2 meters at length and its side length is 1062mm while the thickness is 35mm. It shapes like a half of a hexagon and is reinforced by ribs at the thickness of 70mm every 500mm in longitudinal direction [Figure 4].

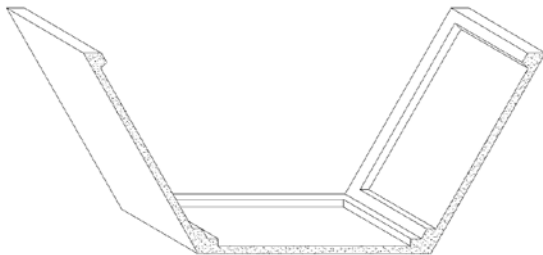

Figure 4. Cross section of the product

The rebar is shaped like “Ω” shape (two ends embedded in the product and the middle part is exposed out), made by Φ8 galvanized steel, every 650mm during GRC product production. When the GRC formwork is installed, an “S” rebar made of Φ8 galvanized steel is connected to the embedded “Ω” rebar on one end and to the beam-post concrete frame on the other end, strengthening the connection between GRC formwork and concrete structure [Figure 5].

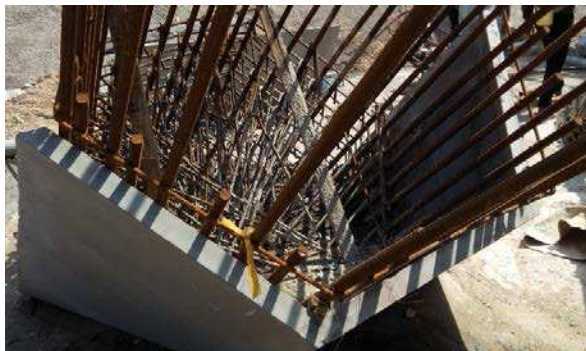

Figure 5. Product installation

CALCUALTION PROCESS

The load combination calculation is done by considering dead loads of formwork, newly casted concrete, steel bars, gravity during concrete compaction, lateral force of concreting (including: concreting speed, initial setting time, pouring height, concrete slump, gravity, pouring temperature and additives etc.,) and verified by the formwork bottom panel which endures greater forces ($S=0.0899N/$). By taking advantage of finite element software ANSYS14.5 (Units: mm, g, N), we found the above product is qualified in strength and deflection.

The formwork load characteristic value is verified by the longer pillar that has a larger angle with the vertical line.

Load characteristic value of the bottom formwork

Assuming S is the pillar section area, b is the bottom side length, l is the pillar length, α is the angle, ρ is concrete density, then the load is as following [Figure 6]:

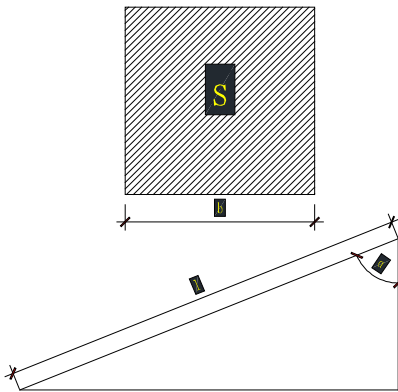

Figure 6. Load diagram

$$p = (\rho \times S \times l \times \sin \alpha) / (b \times l) = (\rho \times S \times \sin \alpha) / b$$

Deadweight standard value of formwork G1K:

$$G1K = 1.7 \text{ kN/}$$

Deadweight standard value of newly casted concrete G2K: let's assume the forces are all undertaken by formwork bottom pane and the largest angle between pillar and vertical line is 68° , then the standard value is as following:

$$G2K = 24.5 \times 2.5 \times \sin 68^\circ / 0.981 = 57.9 \text{ kN/}$$

Deadweight standard value of rebar G3K: pillar rebar is about 2kN/, let's assume the forces are all undertaken by formwork bottom panel and the largest angle between pillar and vertical line is 68° , then the standard value is as following:

$$G3K = 2 \times 2.5 \times \sin 68^\circ / 0.981 = 4.7 \text{ kN/}$$

Standard value of concrete compaction Q2K:

$$Q2k = 4 \text{ kN/}$$

Load standard value of formwork side panel

Stress of the formwork side panel caused by concrete pouring G4K: As per Technical Code for Safety of Formworks in Construction, the biggest lateral stress of formwork caused by newly casted concrete can be calculated as per following equation by taking the smaller value:

$$F = 0.22 \gamma_c t \alpha \beta_1 \beta_2 \sqrt{v}$$

$$F = \gamma_c h$$

In the equation,

γ_c – concrete density is 24.5kN/;

t_c – Initial setting time of newly casted concrete is about 4 hours ;

T – Concrete pouring temperature;

V – Pouring speed (m/h);

H – Total height used for concrete lateral pressure calculation

h – Total height between concrete lateral pressure calculation position and newly casted concrete top

β_1 – Correction factor of additives is 1.2;

β_2 – Correction factor of concrete slump, when the slump is less than 30mm, take 0.85 into the equation, between 50mm and 90mm, take 1.0, while between 110mm and 220mm, take 1.15.

In accordance with the above two equations, the smaller value F is the biggest lateral pressure of the newly casted concrete;

Effective pressure height: $h = \text{Error!}$

Based on the pouring speed ($v=2\text{m/h}$) and initial setting time ($t_c=4\text{hours}$), $h = 3.79\text{m}$.

$$\begin{aligned} F_1 &= 0.22 \times 24.5 \times 4 \times 1.2 \times 1.15 \times \sqrt{2} \\ &= 42.1 \text{ kN/} \end{aligned}$$

$$\begin{aligned} F_2 &= 24.5 \times 3.79 \\ &= 92.9 \text{ kN/} \end{aligned}$$

The smaller value 42.1kN/ is taken as the biggest lateral stress G4K in this project.

Load combinations

Load combination used for calculating the formwork bottom panel bearing ability:

$$\begin{aligned} S &= 1.35 \times G1K + 1.35 \times G2K + 1.35 \times G3K + 1.4 \times 0.7 \times Q2K \\ &= 1.35 \times 1.7 + 1.35 \times 57.9 + 1.35 \times 4.7 + 1.4 \times 0.7 \times 4 \\ &= 89.9 \text{ kN/} \end{aligned}$$

Load combination used for calculating the formwork bottom panel deflection:

$$\begin{aligned} S &= G1K + G2K + G3K \\ &= 1.7 + 57.9 + 4.7 \\ &= 64.3 \text{ kN/} \end{aligned}$$

Load combination used for calculating the formwork side panel bearing ability:

$$\begin{aligned} S &= 1.35 \times G4K + 1.4 \times 0.7 \times Q2K \\ &= 1.35 \times 42.1 + 1.4 \times 0.7 \times 4 \\ &= 60.8 \text{ kN/} \end{aligned}$$

Load combination used for calculating the formwork side panel deflection:

The formwork bottom panel bearing greater stress is taken for pressure verification,

$$S=89.9\text{kN/m}^2$$

$$=0.0899\text{N/}$$

GRC panel design

Parameters of the product

Take a typical GRC panel for the analysis, its cross section shapes like a hexagon, the length is 2 meter and thickness is 35mm. The four ribs, 35mm in height and 100 in width, are evenly distributed along the panel length.

The finite element software ANSYS14.5 is used for analysis (Units: mm, g, N). Finite element model and the distributed load model coupled with the calculation of strength and deflection are shown in [Figure 7].

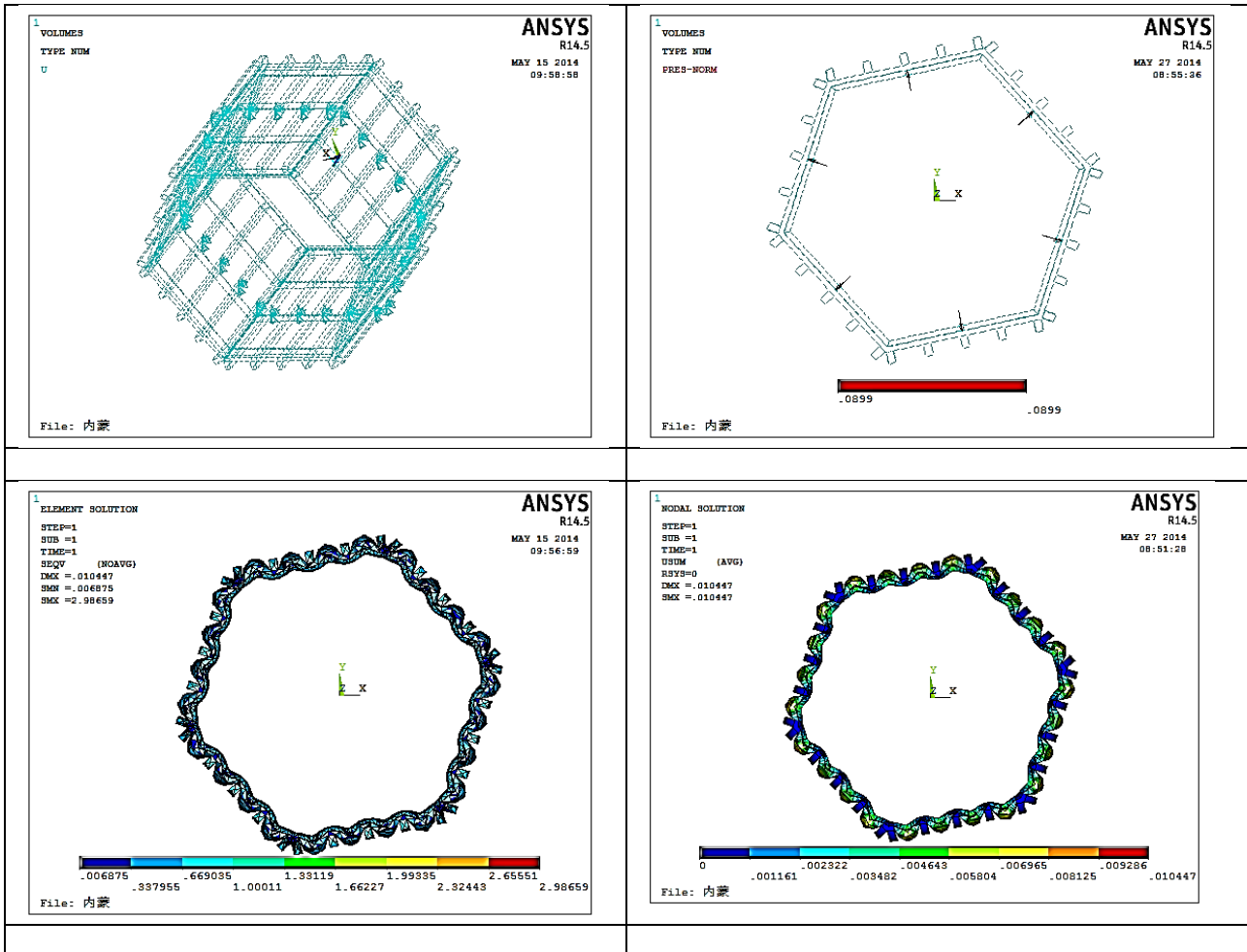

Figure 7. Finite Elements Analysis

Calculations are as following:

Effective stress: $\sigma = 2.99\text{N}/<6\text{N}/$ Strength qualified!
Deflection: $DF = 0.01\text{mm}<L/240$
 $= 200/240 = 0.833\text{mm}$ Deflection qualified!

As mentioned above, under these conditions, the formwork is qualified!

The production is composed of mold fabrication, product manufacturing, curing and demoulding. Two types of molds are used in production, wooden mold used for manufacturing simple product and FRP mold used for producing complex curved product. Based on product features, 5 pieces of wooden masters were made for FRP mold fabrication. The largest wooden master takes up over 150 square meters, divided and produced by 33 molds, among which the largest wooden mold is about 13 square meters. The whole project consumes 161 molds and over 900 square meters of products. GRC production is carried out according to the project requirement and schedule. Because of the smaller workshop, molds were taken into production in different batches and placed reasonably so as to make good use of space. Manufacturing in an open air, in order to produce 300 square meters of products every day, three screw cars, two high-shear mixers, two screw air compressors (Desran), and multiple canopies were equipped. An auto crane of 25T was rent for product demoulding and handling etc.

SUPPORTING AND FASTENING

Four-way ring system scaffolding is used for the installation, pole span is 900x1200 (the span is 600x600 and 600x900 where greater bearing ability is required). On top of the poles, the longer "I" steels (at the height of 140mm) will be used as supporting beams which are perpendicular to the formwork. On the beams, wooden columns (100x100x2000mm) will be placed at the distance no more than 250mm, and reinforced by other I beams at the distance no more than 650mm. The GRC formwork strength is rechecked and meets the design requirement based on such kind of supporting system. The calculation is omitted.

Because many construction elements are of curved shapes, the positioning of bottom formwork was a relatively difficult job during installation. The construction process goes like this: the scaffold is erected first, based on which supporting beams and wooden columns are installed, later on, the bottom formwork is lifted and installed and adjusted at the exact designed position. The positioning of bottom formwork is relatively complex, three positions on the upper part of the formwork (no positioning is required for the bottom panel, because it seats on another formwork) are taken as installation control points. Before installation, firstly, the planar projection positions (used for formwork positioning) should be marked on the ground, secondly, laser plummet apparatus will be placed at the projection positions and be turned on for projection; finally, leveling instruments shall be used for inspection of the positioning elevations which shall be marked to the adjacent poles. The elevation height of each positioning point should be marked at least on three different poles. Steel wires are then used to connect the poles at the places where elevation heights are marked, a wooden ruler is placed on the wires and pointing to the positioning point. After these preparations, the bottom formwork can be lifted and installed at the exact positioning points by taking advantage of laser plummet apparatus and wooden ruler. Positioning of the bottom formwork can be adjusted by adjusting supporting beams which can be adjusted by changing the height of poles on top of the scaffold [Figure 8].



Figure 8. Installation on site

Assembling reinforcement is carried out when the formwork is installed. Steel bars should be provided continuously during assembling and are forbidden to be stacked on the formwork. When assembling reinforcement finished, $\Phi 12$ split bolt shall be mounted at the distance of 800mm. Then, the top formwork will be lifted and installed, its positioning is relatively simple and will be omitted in this paper. When a set of formwork is installed, the wood supports will be provided and reinforced by welding steel anchor ears. PU FOAM shall be used to fill the gap between the formworks.

The construction process is shown in [Figure 9].

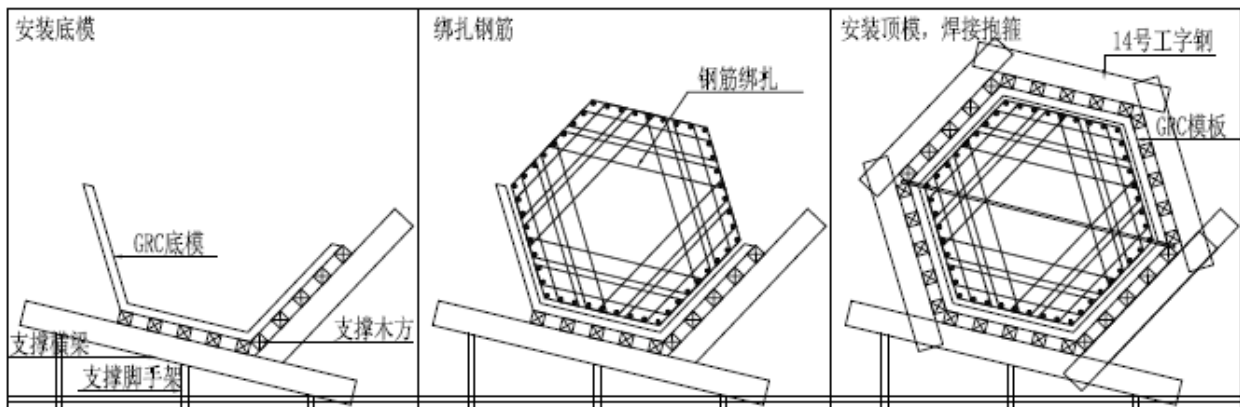

Figure 9. Sketch of construction process

CONCRETE POURING

Because of the complex and larger cross section of the construction structure, self-compacting concrete is used in the construction and high strength grouting method is applied at the extreme complex areas, which is in line with normal civil engineering practices and is omitted here.

During pouring, no swelling, shifting or grout leakage was found on formworks. After pouring and dismantling of fasteners [Figure 10], some places on formworks were deliberately damaged to

check the concreting quality but no hollows were found which proved that the concreting was of good compactness.



Figure 10. Fasteners dismantling after pouring

CONCLUSION

GRC product can be used extensively and the application of permanent formwork can be further developed in the future. With many years of rich experience in GRC fabrication and installation, I illustrated some brief introduction as expressed in this paper.

References:

- [1] "Unified standard for constructional quality acceptance of building engineering"(GB50300-2001)
- [2] "Load code for the design of building structures"(GB 50009-2012)
- [3] "Code for design of concrete structure"(GB 50010-2010)
- [4] "Code for design of steel structures"(GB 50017-2003)
- [5] "Technical code for safety of forms in construction"(JGJ 162-2008)
- [6] "Glass fiber reinforced cement wall panel" JC/T1057-2007